

Technical Data Sheet

ARCAPRO® Positioner Type 827A



TD_827A

General data

Mounting	On linear actuators	ARCA-integrated or to VDI/VDE 3847-1 or IEC 534-6 (NAMUR) Range of stroke: 3 ... 130 mm
	On quarter turn actuators	Integrated to VDI/VDE 3847-2 or VDI/VDE 3845 Angle of rotation: 30 ... 100°
Enclosure material	Metal	Aluminium cast AlSi 12 or austenitic stainless steel 1.4581
	Plastic	Glass-fibre-reinforced polycarbonate
Degree of protection		IP 66 to EN 60529
Installation position		Any installation position possible; pneumatic connections and exhaust opening must not point upwards for wet applications
Climate class	Operation	4K3, but -30 ... +80 °C (Standard and FIP) -40...+80 °C (LT) (see electrical data for explosion-protected devices)
	Storage	1K5, but -40 ... +80 °C
	Transport	2K4, but -40 ... +80 °C
Vibration resistance		98 m/s ² , 27 ... 300 Hz Recommended continuous range for complete fitting ≤ 30 m/s ²
Classification according PED97/23/EC		For fluid group 1 gases; fulfils requirements in article 3, paragraph 3 (good engineering practice)
CE marking		Applicable directives and standards see declaration of conformity
Controller unit	Five-point switch	Adaptive
	Dead zone	Adaptive or fixed from 0.1 ... 10 %
	Actuating times	≥1.5 s adjustable
A/D converter	Resolution	≤ 0.5 %
	Sampling time	10 ms
Cycle time	With / without HART communication	20 ms
	With PROFIBUS PA communication	60 ms
	With Fieldbus Foundation communication	60 ms
Dimensions		See dimension drawings 1 to 4
Weight	Metal enclosure, aluminium	Approx. 1.3 kg
	Metal enclosure, stainless steel	Approx. 3.9 kg
	Metal enclosure, flame-proof	Approx. 5.2 kg
	Plastic enclosure	Approx. 0.9 kg
Connections	Electric	Screw terminals 2.5 AWG28-12; cable inlet see order key
	Pneumatic	G 1/4 DIN 45141 or 1/4-18NPT, see order key

Technical Data Sheet

ARCAPRO® Positioner Type 827A



TD_827A

Pneumatic data

Operation	Standard	At failure of electrical or pneumatic energy exhausting
Option	Fail In Place	At failure of electrical or pneumatic energy blocking
Inlet air pressure		1.4 ... 7 bar (Standard) / 3...7 bar (FIP)
Air quality	Solids	ISO 8573-1 Class 2 (particle size ≤ 1 µm, particle density ≤ 1 mg/Nm ³)
	Dew point	ISO 8573-1 Class 2 (-40 °C, min. 20 K below ambient temperature)
	Oil content	ISO 8573-1 Class 2 (≤ 0.1 mg/Nm ³)
Air consumption		< 36 Ndm ³ /h during stationary operation
Flow rate (unthrottled)	Air supply valve at Δp	2 bar - 4.1 Nm ³ /h, 4 bar - 7.1 Nm ³ /h, 6 bar - 9.8 Nm ³ /h
	Air exhaust valve at Δp	2 bar - 8.2 Nm ³ /h, 4 bar - 13.7 Nm ³ /h, 6 bar - 19.2 Nm ³ /h 2 bar - 4.3 Nm ³ /h, 4 bar - 7.3 Nm ³ /h, 6 bar - 9.8 Nm ³ /h
Valve leakage		< 0.6 Ndm ³ /h
Throttle ratio		Up to ∞ : 1 adjustable

Electrical data for basic device

Explosion protection	Intrinsic safety "ia"	II2G Ex ia IIC T6/T4 Gb ¹⁾ , Zone 1, II2D Ex ia IIIC T110°C Db, Zone 21 ²⁾
	Intrinsic safety "ic"	II3G Ex ic IIC T6/T4 Gc ¹⁾ , Zone 2 ²⁾
	Non-sparking, "nA"	II3G Ex nA IIC T6/T4 Gc ¹⁾ , Zone 2 ²⁾
	Dust, protection by enclosure "t" ³⁾	II2D Ex tb IIIC T100°C Db, Zone 21 ²⁾
	Flameproof "d"	II2G Ex d IIC T6/T4, Zone 1 ²⁾
Permissible ambient temperature	"ia", "ic", "nA"	T4 / T6 - 30 ... + 80 °C / - 30 ... + 50 °C (Standard and FIP) T4 / T6 - 40 ... + 60 °C / - 40 ... + 50 °C (LT)
	"t"	- 30 ... + 80 °C (Standard and FIP) - 40 ... + 80 °C (LT)
	"d"	T4 / T6 - 30 ... + 80 °C / - 30 ... + 50 °C

¹⁾ With analogue module T4 only

²⁾ On request

³⁾ Without contact module

Technical Data Sheet

ARCAPRO® Positioner Type 827A



TD_827A

Electrical data for basic device with / without HART 2 wire connection

Explosion protection	without, "d"	„ia“	„ic“	“nA”, “t”
Electrical connection	See Figures 5 and 6	See Figures 5 and 6	See Figures 5 and 6	See Figures 5 and 6
Communication	HART version 7			
Input signal I_w	4 ... 20 mA	4 ... 20 mA	4 ... 20 mA	4 ... 20 mA
Current to maintain the power supply	≥ 3.6 mA	≥ 3.6 mA	≥ 3.6 mA	≥ 3.6 mA
Required load voltage without HART 2 wire device	6.5 V	8.3 V	8.3 V	8.3 V
Required load voltage without HART 2/3/4 wire device	8.4 V	-	-	-
Required load voltage with HART 2 wire device	6.7 V	-	-	-
Required load voltage with HART 2/3/4 wire device	-	8.8 V	8.8 V	8.8 V
Static destruction limit	± 40 mA	-	-	± 40 mA
For connection to	-	certified intrinsically safe circuits with max. U _i = 30 V I _i = 100 mA P _i = 1 W	intrinsically safe circuits with max U _i = 30 V I _i = 100 mA	circuits with max. U _n = 30 V I _n = 100 mA
Internal capacitance	-	11 nF	11 nF	-
Internal inductance	-	207 µH without HART 310 µH with HART	207 µH without HART 310 µH with HART	-
Binary input BE1	Suitable for dry contact, max. contact load ≤ 5 µA at 3 V			
Electrical isolation	I _w and BE1 electrically connected	I _w and BE1 electrically connected	I _w and BE1 electrically connected	I _w and BE1 electrically connected

Technical Data Sheet

ARCAPRO® Positioner Type 827A



TD_827A

Electrical data for basic device with / without HART 3/4 wire connection

Explosion protection	without, "d"	„ia“	“ic”	“nA”, “t”
Electrical connection	See Figure 7	See Figure 7	See Figure 7	See Figure 7
Communication	HART version 7			
Input signal I_w	0/4 ... 20 mA	0/4 ... 20 mA	0/4 ... 20 mA	0/4 ... 20 mA
Required load voltage	0.2 V	1.0 V	1.0 V	1.0 V
Power supply U_H	DC 18 ... 35 V	DC 18 ... 30 V	DC 18 .. 30 V	DC 18 ... 30 V
For connection to	-	certified intrinsically safe circuits with max. U _i = 30 V I _i = 100 mA P _i = 1 W	intrinsically safe circuits with max U _i = 30 V I _i = 100 mA	circuits with max. U _n = 30 V I _n = 100 mA
Internal capacitance	-	22 nF	22 nF	-
Internal inductance	-	0.12 mH	0.12 mH	-
Binary input BE1	Suitable for dry contact, max. contact load ≤ 5 µA at 3 V			
Electrical isolation	U _H and I _w electrically isolated, I _w and BE1 electrically connected	U _H and I _w electrically isolated, I _w and BE1 electrically connected	U _H and I _w electrically isolated, I _w and BE1 electrically connected	U _H and I _w electrically isolated, I _w and BE1 electrically connected

Electrical data for basic device PROFIBUS PA

Electrical connection	See Figure 8
Communication	Layers 1 + 2 to PROFIBUS PA, transmission technique to IEC 1158-2, slave function layer 7 to PROFIBUS DP to EN 50170 with extended PROFIBUS functionality
Device profile	PROFIBUS PA profile B, version 3.0, over 150 objects
Response time for a master telegram	typically 10 ms
Device address	126 in the as-delivered condition

Electrical data for basic device Foundation Fieldbus

Electrical connection	See Figure 9
Communication	H1 communication to specification of the Fieldbus Foundation, group 3, class 31 PS (Publisher/Subscriber) 1 resource block (RB2), 1 analogue output function block (AO), 1 PID function block (PID), 1 transducer block (standard advanced positioner valve)
Physical layer profile	123, 511
Block execution times	Analogue output function block 60 ms; PID function block 80 ms

Technical Data Sheet

ARCAPRO® Positioner Type 827A



TD_827A

Electrical data for basic device PROFIBUS PA / Foundation Fieldbus

Explosion protection	without, "d"	„ia“	“ic”	“nA”, “t”
Power supply	Bus-powered	Bus-powered	Bus-powered	Bus-powered
Bus voltage	DC 9 ... 32 V	DC 9 ... 24 V	DC 9 ... 32 V	DC 9 ... 32 V
Current consumption	10.5 mA ± 10 %	10.5 mA ± 10 %	10.5 mA ± 10 %	10.5 mA ± 10 %
Fault current	0	0	0	0
For connection to	-	circuits with certified FISCO power supply with max. U _i = 17,5 V I _i = 380 mA P _i = 5,32 W	circuits with FISCO power supply with max U _i = 17,5 V I _i = 570 mA	circuits with max. U _n = 30 V I _n = 100 mA
	-	circuits with certified barrier with max. U _i = 17,5 V I _i = 380 mA P _i = 5,32 W	circuits with barrier with max U _i = 17,5 V I _i = 570 mA	
Internal capacitance	-	Negligible small	Negligible small	-
Internal inductance	-	8 µH	8 µH	-
Safety shutdown				
Input resistance	> 20 kΩ	> 20 kΩ	> 20 kΩ	> 20 kΩ
Signal status 0: active	DC 0 ... 4.5 V	DC 0 ... 4.5 V	DC 0 ... 4.5 V	DC 0 ... 4.5 V
Signal status 1: inactive	DC 13 ... 30 V	DC 13 ... 30 V	DC 13 ... 30 V	DC 13 ... 30 V
For connection to	-	certified intrinsically safe circuits with max. U _i = 30 V I _i = 100 mA P _i = 1 W	intrinsically safe circuits with max U _i = 30 V I _i = 100 mA	circuits with max. U _n = 30 V I _n = 100 mA
Internal capacitance	-	Negligible small	Negligible small	-
Internal inductance	-	Negligible small	Negligible small	-
Binary input BE1	Suitable for dry contact, max. contact load ≤ 5 µA at 3 V			
Electrical isolation	Bus connection and safety shutdown electrically isolated, Bus connection and BE1 electrically connected	Bus connection and safety shutdown electrically isolated, Bus connection and BE1 electrically connected	Bus connection and safety shutdown electrically isolated, Bus connection and BE1 electrically connected	Bus connection and safety shutdown electrically isolated, Bus connection and BE1 electrically connected

Technical Data Sheet

ARCAPRO® Positioner Type 827A



TD_827A

Electrical data for option modules – analogue module

Explosion protection	without, "d"	„ia“	“ic”	“nA”, “t”
Electrical connection	See Figure 10	See Figure 10	See Figure 10	See Figure 10
Nominal signal range	4...20 mA, short circuit resistant	4...20 mA, short circuit resistant	4...20 mA, short circuit resistant	4...20 mA, short circuit resistant
Dynamic range	3.6...20.5 mA	3.6...20.5 mA	3.6...20.5 mA	3.6...20.5 mA
Auxiliary voltage U_H	+12...+35 V	+12...+30 V	+12...+30 V	+12...+30 V
External load R_B [k Ω]	$(U_H [V] - 12)/I [mA]$	$(U_H [V] - 12)/I [mA]$	$(U_H [V] - 12)/I [mA]$	$(U_H [V] - 12)/I [mA]$
For connection to	-	certified intrinsically safe circuits with max. $U_i = 30$ V $I_i = 100$ mA $P_i = 1$ W	intrinsically safe circuits with max $U_i = 30$ V $I_i = 100$ mA	circuits with max. $U_n = 30$ V $I_n = 100$ mA $P_n = 1$ W
Internal capacitance	-	11 nF	11 nF	-
Internal inductance	-	Negligible small	Negligible small	-
Electrical isolation	Disconnected from basic device	Disconnected from basic device	Disconnected from basic device	Disconnected from basic device

Electrical data for option modules – binary module

Explosion protection	without, "d"	„ia“	“ic”	“nA”, “t”
Electrical connection	See Figure 11	See Figure 11	See Figure 11	See Figure 11
Binary outputs A1, A2, fault				
Signal status “High” (not responded)	Conductive, $R = 1$ k Ω ¹⁾	≥ 2.1 mA ²⁾	≥ 2.1 mA ²⁾	≥ 2.1 mA ²⁾
Signal status “Low” (responded)	Blocked, $I_R < 60$ μ A	≤ 1.2 mA ²⁾	≤ 1.2 mA ²⁾	≤ 1.2 mA ²⁾
For connection to	-	certified intrinsically safe circuits with max. $U_i = 15$ V $I_i = 25$ mA $P_i = 64$ mW	intrinsically safe circuits with max $U_i = 15$ V $I_i = 25$ mA	circuits with max. $U_n = 15$ V $I_n = 25$ mA
Internal capacitance	-	5,2 nF	5,2 nF	-
Internal inductance	-	Negligible small	Negligible small	Negligible small

¹⁾ – Current must be restricted to 10 mA per output if operated in flameproof housing.

²⁾ – Switching thresholds for supply to EN 60947-5-6: $U_H = 8.2$ V, $R_i = 1$ k Ω

Technical Data Sheet

ARCAPRO® Positioner Type 827A



TD_827A

Electrical data for option modules – binary module (continuation)

Explosion protection	without, "d"	„ia“	“ic”	“nA”, “t”
Binary input BE2 Terminals 11/12			-	-
Auxiliary voltage U _H	≤ DC 35 V ≤ 20 mA	-	-	-
Signal status 0:	≤ DC 4.5 V or open	≤ DC 4.5 V or open	≤ DC 4.5 V or open	≤ DC 4.5 V or open
Signal status 1:	≥ DC 13 V	≥ DC 13 V	≥ DC 13 V	≥ DC 13 V
Input resistance	> 25 kΩ	> 25 kΩ	> 25 kΩ	> 25 kΩ
Static destruction limit	± 35 V	-	-	-
For connection to	-	certified intrinsically safe circuits with max. U _i = 25,2 V	intrinsically safe circuits with max U _i = 25,2 V	circuits with max. U _n = 25,2 V
Internal capacitance	-	Negligible small	Negligible small	-
Internal inductance	-	Negligible small	Negligible small	-
Binary input BE2 Terminals 21/22				
Signal state 0:	Dry contact, open	Dry contact, open	Dry contact, open	Dry contact, open
Signal state 1:	Dry contact, closed	Dry contact, closed	Dry contact, closed	Dry contact, closed
Contact load	3 V, 5 μA	3 V, 5 μA	3 V, 5 μA	3 V, 5 μA
Electrical isolation	Binary outputs A1, A2, fault, binary input BE2 terminals 11/12 disconnected from basic device; binary input BE2 terminals 21/22 connected to basic device	Binary outputs A1, A2, fault, binary input BE2 terminals 11/12 disconnected from basic device, binary input BE2 terminals 21/22 connected to basic device	Binary outputs A1, A2, fault, binary input BE2 terminals 11/12 disconnected from basic device; binary input BE2 terminals 21/22 connected to basic device	Binary outputs A1, A2, fault, binary input BE2 terminals 11/12 disconnected from basic device; binary input BE2 terminals 21/22 connected to basic device

Technical Data Sheet

ARCAPRO® Positioner Type 827A



TD_827A

Electrical data for option modules – slot initiator module

Explosion protection	without, “d”	„ia“	“ic”	“nA”, “t”
Electrical connection	See Figure 12	See Figure 12	See Figure 12	See Figure 12
Binary outputs A1, A2	Slotted initiators SJ2-SN to EN 60947-5-6 (NAMUR) for connecting to switching amplifier, NC (normally closed) function			
Signal state “High” (not responded)	$\geq 3 \text{ mA}$ at $U_{nom} = 8 \text{ V}$	$\geq 2.1 \text{ mA}^1)$	$\geq 2.1 \text{ mA}^1)$	$\geq 2.1 \text{ mA}^1)$
Signal state “Low” (responded)	$\leq 1 \text{ mA}$ at $U_{nom} = 8 \text{ V}$	$\leq 1.2 \text{ mA}^1)$	$\leq 1.2 \text{ mA}^1)$	$\leq 1.2 \text{ mA}^1)$
For connection to	$U_{nom} = 8 \text{ V}$	certified intrinsically safe circuits with max. $U_i = 15 \text{ V}$ $I_i = 25 \text{ mA}$ $P_i = 64 \text{ mW}$	intrinsically safe circuits with max $U_i = 15 \text{ V}$ $I_i = 25 \text{ mA}$	circuits with max. $U_n = 15 \text{ V}$ $I_n = 25 \text{ mA}$
Internal capacitance	-	41 nF	41 nF	-
Internal inductance	-	100 μH	100 μH	-
Binary output fault				
Signal status “High” (not addressed)	$R = 1,1 \text{ k}\Omega$	$\geq 2.1 \text{ mA}^1)$	$\geq 2.1 \text{ mA}^1)$	$\geq 2.1 \text{ mA}^1)$
Signal status “Low” (addressed)	$R = 10 \text{ k}\Omega$	$\leq 1.2 \text{ mA}^1)$	$\leq 1.2 \text{ mA}^1)$	$\leq 1.2 \text{ mA}^1)$
For connection to	$U_H \leq 35 \text{ V}$ $I \leq 20 \text{ mA}$	certified intrinsically safe circuits with max. $U_i = 15 \text{ V}$ $I_i = 25 \text{ mA}$ $P_i = 64 \text{ mW}$	intrinsically safe circuits with max $U_i = 15 \text{ V}$ $I_i = 25 \text{ mA}$	circuits with max. $U_n = 15 \text{ V}$ $I_n = 25 \text{ mA}$
Internal capacitance	-	5.2 nF	5.2 nF	-
Internal inductance	-	Negligible small	Negligible small	-
Electrical isolation	Binary outputs A1, A2, fault disconnected from basic device	Binary outputs A1, A2, fault disconnected from basic device	Binary outputs A1, A2, fault disconnected from basic device	Binary outputs A1, A2, fault disconnected from basic device

¹⁾ – Switching thresholds for supply to EN 60947-5-6: $U_H = 8.2 \text{ V}$, $R_i = 1 \text{ k}\Omega$

Technical Data Sheet

ARCAPRO® Positioner Type 827A



TD_827A

Electrical data for option modules – contact module

Explosion protection	without, “d”	„ia“	“ic”	“t”
Electrical connection	See Figure 13	See Figure 13	See Figure 13	See Figure 13
Binary outputs A1, A2	dry contacts			
Max. switching current	4 A AC / DC	-	-	-
Max. switching voltage	250 V AC, 24 V DC	-	-	-
For connection to	-	certified intrinsically safe circuits with max. $U_i = 30 \text{ V}$ $I_i = 100 \text{ mA}$ $P_i = 750 \text{ mW}$	intrinsically safe circuits with max $U_i = 30 \text{ V}$ $I_i = 100 \text{ mA}$	circuits with max. $U_n = 30 \text{ V}$ $I_n = 100 \text{ mA}$
Internal capacitance	-	Negligible small	Negligible small	-
Internal inductance	-	Negligible small	Negligible small	-
Binary output fault				
Signal status “High” (not responded)	$R = 1,1 \text{ k}\Omega$	$\geq 2.1 \text{ mA}^1)$	$\geq 2.1 \text{ mA}^1)$	$\geq 2.1 \text{ mA}^1)$
Signal status “Low” (responded)	$R = 10 \text{ k}\Omega$	$\leq 1.2 \text{ mA}^1)$	$\leq 1.2 \text{ mA}^1)$	$\leq 1.2 \text{ mA}^1)$
For connection to	$U_H \leq 35 \text{ V}$ $I \leq 20 \text{ mA}$	certified intrinsically safe circuits with max. $U_i = 15 \text{ V}$ $I_i = 25 \text{ mA}$ $P_i = 64 \text{ mW}$	intrinsically safe circuits with max $U_i = 15 \text{ V}$ $I_i = 25 \text{ mA}$	circuits with max. $U_n = 15 \text{ V}$ $I_n = 25 \text{ mA}$
Internal capacitance	-	5.2 nF	5.2 nF	-
Internal inductance	-	Negligible small	Negligible small	-
Electrical isolation	Binary outputs A1, A2, fault disconnected from basic device	Binary outputs A1, A2, fault disconnected from basic device	Binary outputs A1, A2, fault disconnected from basic device	Binary outputs A1, A2, fault disconnected from basic device

¹⁾ – Switching thresholds for supply to EN 60947-5-6: $U_H = 8.2 \text{ V}$, $R_i = 1 \text{ k}\Omega$

Technical Data Sheet ARCAPRO® Positioner Type 827A



TD_827A

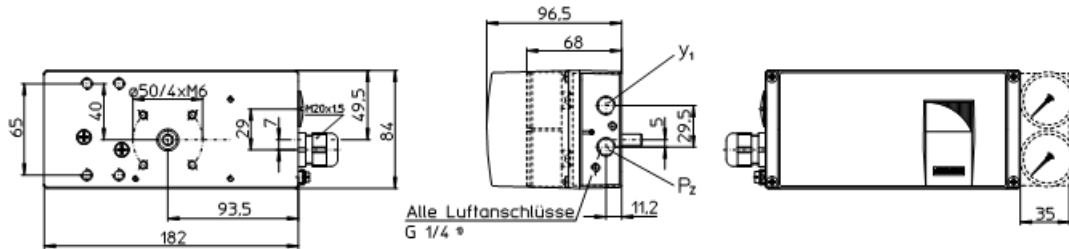

Figure 1 Metal enclosure, standard

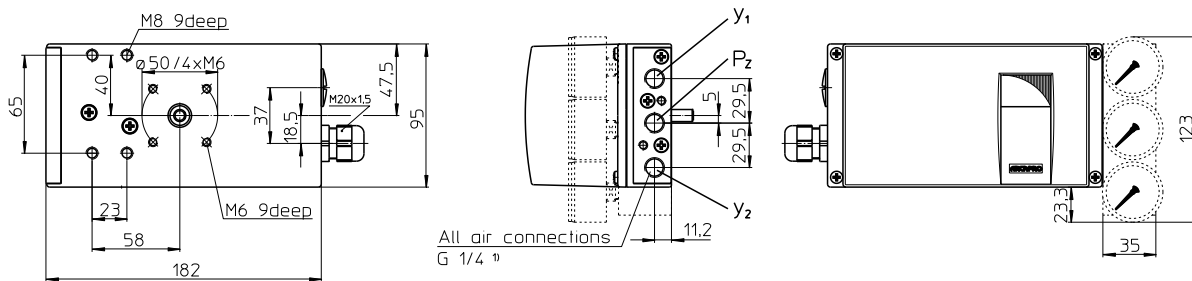

Figure 2 Plastic enclosure

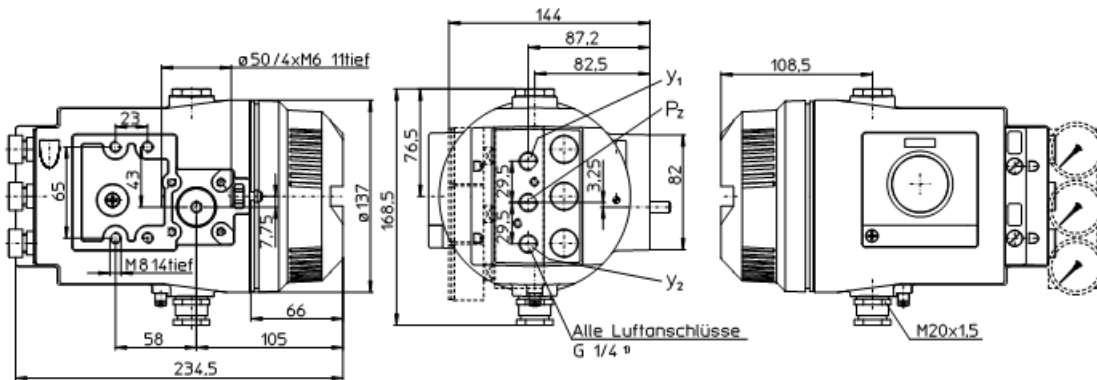

Figure 3 Metal enclosure, flameproof

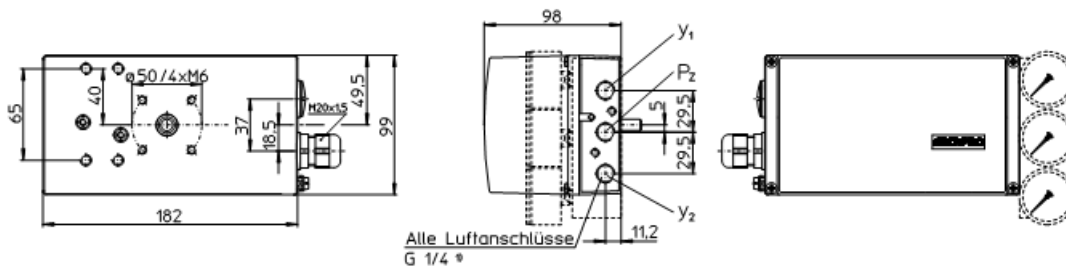

Figure 4 Metal enclosure, stainless steel

Technical Data Sheet ARCAPRO® Positioner Type 827A



TD_827A

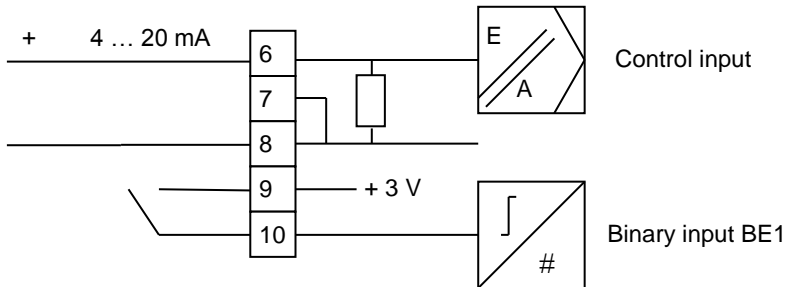

Figure 5 Electrical connection of 2 wire basic device

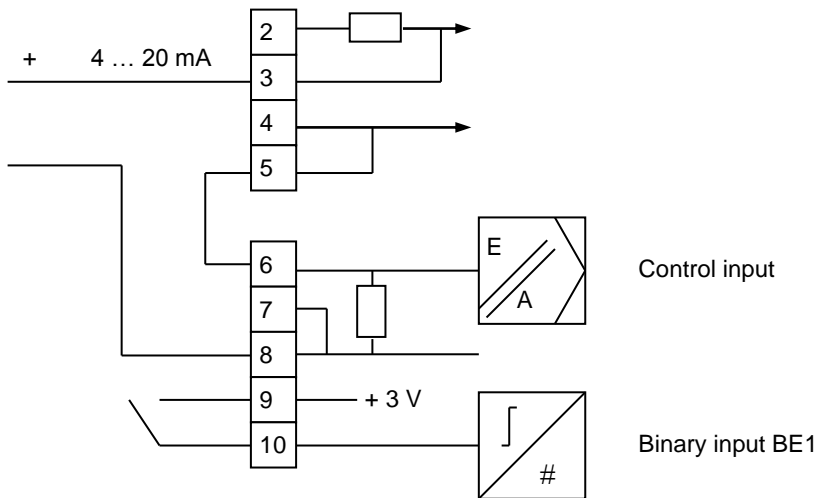

Figure 6 Electrical connection of 2/3/4 wire base device, 2 wire connection

Technical Data Sheet ARCAPRO® Positioner Type 827A



TD_827A

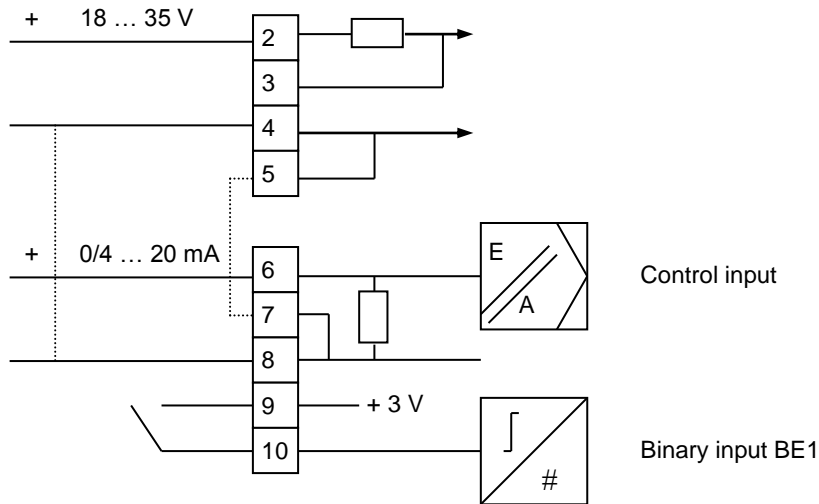

Figure 7 Electrical connection of 2/3/4 wire base device, 3/4 wire connection

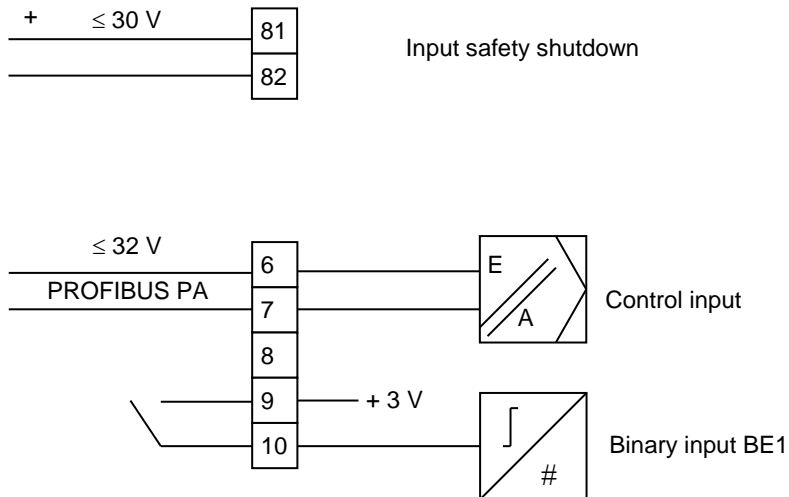

Figure 8 Electrical connection of base device, PROFIBUS PA

Technical Data Sheet ARCAPRO® Positioner Type 827A



TD_827A

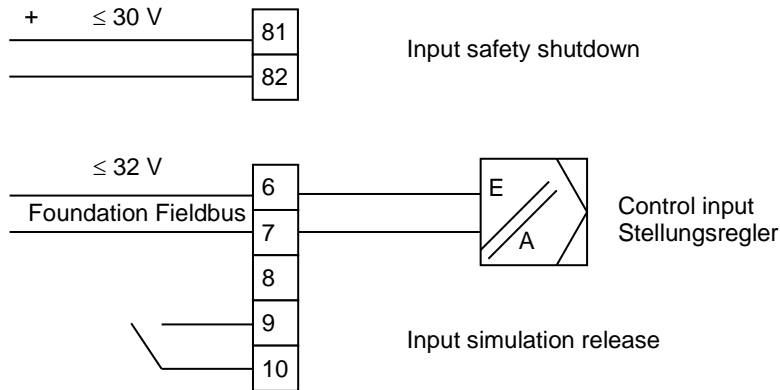

Figure 9 Electrical connection of base device, Fieldbus Foundation

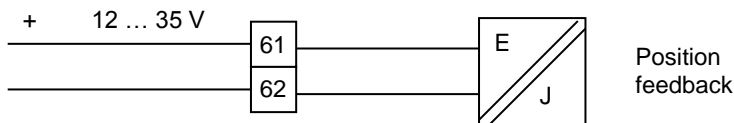

Figure 10 Electrical connection of analogue module

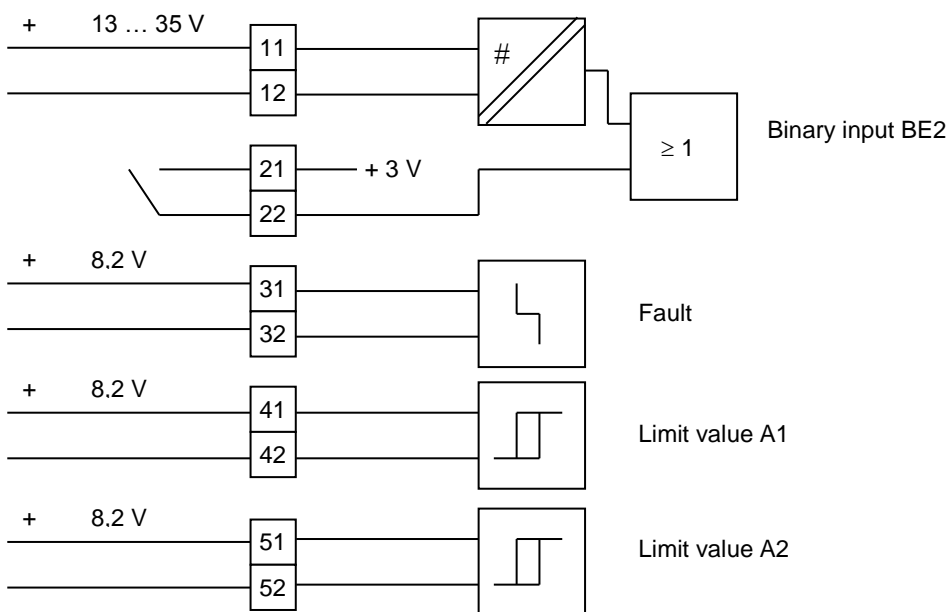

Figure 11 Electrical connection of binary module

Technical Data Sheet ARCAPRO® Positioner Type 827A



TD_827A

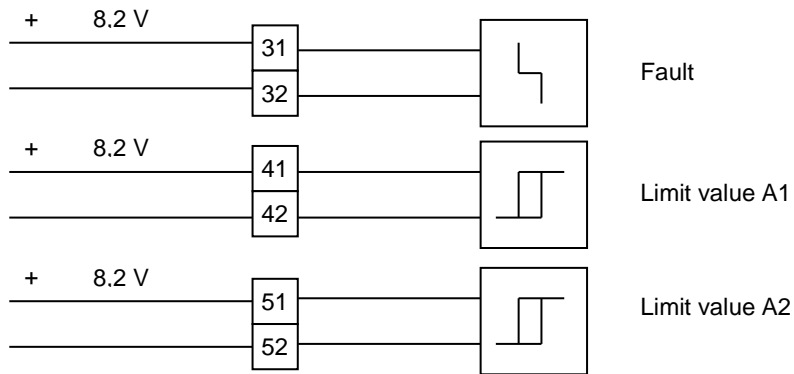

Figure 12 Electrical connection of slot initiator module

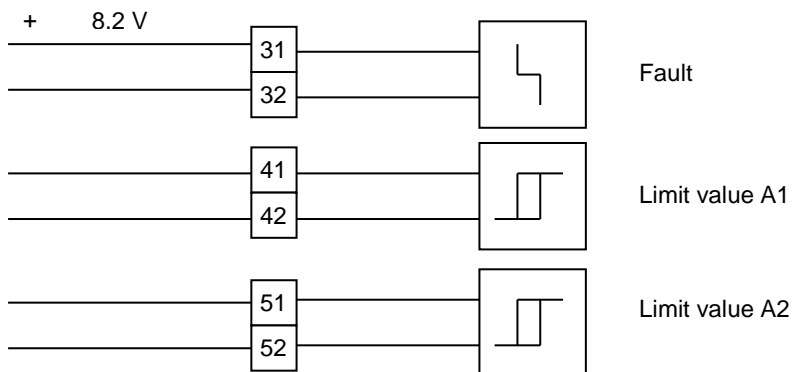

Figure 13 Electrical connection of contact module

Technical Data Sheet

ARCAPRO® Positioner Type 827A



TD_827A

Order keys for ARCAPRO® type 827A

1. Series		7. Enclosure material	
827A		M	Aluminium (single-acting only)
2. Explosion protection ¹⁾			Plastic ⁶⁾ , ⁷⁾
E	Without	E	Stainless steel ⁶⁾
X	Explosion-proof "ia" II2G ²⁾	8. Pneumatics	
	Explosion-proof "ia" II2D, "ic" ²⁾ , ³⁾ , ⁷⁾	1	Single-acting
	Explosion-proof "nA", "t" ²⁾ , ⁴⁾ , ⁷⁾	2	Double-acting (aluminium housing excluded)
	Explosion-proof "d" ⁷⁾		
3. Connection of base device		9. Mechanical actuation	
2	2 wire	0	Standard
4	2/3/4 wire ⁵⁾	1	with internal non contacting sensor ⁷⁾
		2	None (for external sensor)
4. Analogue output		10. Connection thread, electric / pneumatic	
0	Without analogue output	G	M20x1.5 / G 1/4
A	Analogue module	N	1/2" NPT / 1/4" NPT
5. Binary output		M	M20x1.5 / 1/4" NPT
0	Without binary output	P	1/2" NPT / G 1/4
B	Binary module	Q	M25x1.5 / 1/4" NPT (EEx d only)
S	Slot initiator module ⁶⁾	R	connector M12 for input signal / G 1/4
K	Contact module ⁶⁾	S	connector M12 for input signal / 1/4" NPT
6. Communication		11. Options	
0	Without communication	FIP	Fail In Place ⁷⁾
H	HART	LT	- 40 °C ⁷⁾
P	PROFIBUS PA	SA	connector M12 for Analogue module ⁷⁾
F	Fieldbus Foundation	SB	connector M12 for Binary module ⁷⁾
		SS	connector M12 for Slot initiator module ⁷⁾
		SW	connector M12 for External stroke sensor ⁷⁾

¹⁾ ATEX approval, other approvals on request

²⁾ With HART communication 2/3/4 wire only

³⁾ Stainless steel housing excluded

⁴⁾ Without inspection window

⁵⁾ PROFIBUS PA and Foundation Fieldbus excluded

⁶⁾ Not for flameproof devices

⁷⁾ On request

Example:

827A.E2-A0H-	<i>Positions 1 - 6</i>
---------------------	------------------------

Positioner 827A – no explosion-proof – 2-wire connection – analogue module – without binary output – HART communication

M10-G-LT	<i>Positions 7 - 11</i>
-----------------	-------------------------

Aluminium enclosure – single-acting – mechanical actuation (standard) – connection thread electric M20x1.5 / pneumatic G 1/4 / - 40 °C

Accessories

Mounting kits	For integrated mounting ARCA linear actuators type 812
	For integrated mounting ARCA linear actuators type 813
	For integrated mounting on linear actuators acc. to VDI/VDE 3847-1
	For mounting on linear actuators acc. to IEC 534 (NAMUR)
	For integrated mounting ARCA quarter turn actuators type 840
	For mounting on quarter turn actuators acc. to VDI/VDE 3845
Pressure gauge blocks	Pressure gauge block for single-acting or double-acting positioner
Extern. position detection	External rotary potentiometer for strokes to 130 mm or external linear potentiometer