

# Technical Data Sheet Positioner Type 824

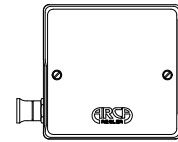

**TD\_824**

## General data

<b>Mounting</b>	On linear actuators	ARCA-integrated or acc. to IEC 534-6 (NAMUR) Range of stroke 10 ... 120 mm
	On quarter-turn actuators	ARCA-integrated or acc. to VDI/VDE 3845 Angle of rotation 90 °
<b>Enclosure material</b>		Aluminium cast / plastic
<b>Degree of protection</b>		IP 54, type 824.D IP 65 acc. to EN 60529
<b>Installation position</b>		Any installation position possible
<b>Climate class</b>	Operation	4K3, but -20 ... +80 °C, low temperature execution -40 ... +80 °C (see electrical data for explosion-protected devices)
	Storage	1K5, but -40 ... +80 °C
	Transport	2K4, but -40 ... +80 °C
<b>Vibration resistance</b>		< 10 g acc. to DIN 89011 Recommended continuous range for complete fittings ≤ 3 g
<b>CE marking</b>		Compliant with EMC Directive 2004/108/EC in accordance with EN 61326 A1 and NAMUR NE21 08.98
<b>Controller data</b>	Gain	max. 100
	Hysteresis	< 0,7 % of the control range
	Response level	< 0,5 % of the control range
	Nonlinearity	< 2 % of the control range
	Supply air influence	< 0,2 % / 0,1 bar, type 824.P < 0,1 % / 0,1 bar
<b>Dimensions</b>		See dimensional drawings figure 1 to 3
<b>Weight</b>	Type 824.P	Approx. 1,8 kg
	Type 824.E and 824.X	Approx. 2,0 kg
	Type 824.D	Approx. 2,8 kg
	Pressure gauge block	Approx. 0,5 kg
<b>Connections</b>	Electric	In dependence of version 0 to 2 cable inlets M20 x 1,5
	Pneumatic with external pipe	(X), Y and Z: collateral G ¼ DIN 45141, special version ¼"NPT, 824.D: behind G ¼ DIN 45141
	Pneumatic with internal pipe	(X), and Z: collateral G ¼ DIN 45141, Y: behind G 1/8 824.D: Z: behind G ¼ DIN 45141, Y: behind G 1/8

# Technical Data Sheet Positioner Type 824

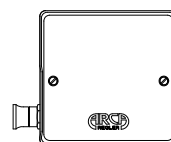

**TD\_824**

## Pneumatic data

<b>Inlet air pressure</b>		1,4...6 barg
<b>Air quality</b>	Solids	ISO 8573-1 Class 2 (particle size $\leq 1 \mu\text{m}$ , particle density $\leq 10 \text{ mg/Nm}^3$ )
	Dew point	ISO 8573-1 Class 2 (- 40 °C, min. 20 K below ambient temperature, low temperature execution < - 50 °C)
	Oil content	ISO 8573-1 Class 2 ( $\leq 0,1 \text{ mg/Nm}^3$ )
<b>Air consumption</b>		< 0,6 Nm <sup>3</sup> /h, type 824.P < 0,5 Nm <sup>3</sup> /h during stationary operation
<b>Flow rate</b>		6 Nm <sup>3</sup> /h at 1,4 barg

## Explosion protection basic device

<b>Explosion protection</b>	Intrinsically safe zone 1+2 (gas)	II 2 G EEx ia IIC T6 EC type-examination certificate TÜV 99 ATEX 1487X	
	Flame-proof	II 2 G EEx d IIC T4/T5/T6 EC type-examination certificate DMT 02 ATEX E121X	
<b>Internal capacitance</b>		Negligible	
<b>Internal inductance</b>		Negligible	
<b>Valid ambient temperature for connection to circuits with ①</b>	T4	- 55 ... + 80 °C	$U_0 \leq \text{DC } 28 \text{ V}$ , $I_K \leq 120 \text{ mA}$ , $P \leq 3,3 \text{ W}$
	T5	- 55 ... + 70 °C	$U_0 \leq \text{DC } 38,8 \text{ V}$ , $I_K \leq 60 \text{ mA}$ , $P \leq 2,3 \text{ W}$
	T6	- 55 ... + 60 °C	$U_0 \leq \text{DC } 42,5 \text{ V}$ , $I_K \leq 50 \text{ mA}$ , $P \leq 2,1 \text{ W}$

## Electrical / pneumatic data basic device

	Pneumatic	Not explosion-proof	Intrinsically safe	Flame-proof
<b>Electrical connection</b>		Figure 4	Figure 4	Figure 4
<b>Input signal</b>	0,2 ... 1 bar	0 / 4 ... 20 mA	0 / 4 ... 20 mA	0 / 4 ... 20 mA
<b>Split ranges</b>	0,2 ... 0,6 ... 1 bar	0 / 4 ... 10 / 12 ... 20 mA	0 / 4 ... 10 / 12 ... 20 mA	0 / 4 ... 10 / 12 ... 20 mA
<b>Load resistance</b>		170 $\Omega$	170 $\Omega$	260 $\Omega$
<b>Required load voltage</b>		3,4 V	3,4 V	5,2 V

# Technical Data Sheet Positioner Type 824

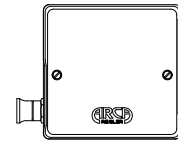

TD\_824

## Electrical data options – inductive limit switches

Version	824.P ...	824.E ...	824.X ...	824.D ...
<b>Limit switch N</b>	824 . [ ] [ ] [ ] [ ] - [ ] [ ] <b>1</b> [ ]			
Normal version	2 wire connection to DIN 19234 (NAMUR), for connected switching amplifier			-
2 slot initiators	Type SJ3,5-N			-
Function	Break contact (NC, normally closed)			-
Hysteresis	≤ 1 %			-
Control loop	See connected switching amplifier			-
Explosion protection zone 1+2 (gas)	-		II 2 G EEx ia IIC T6 ④	-
EC type-examination certificate	-		PTB 99 ATEX 2219 X	-
EMC acc. to	EN 60947-5-2 and DIN 19234			-
Electrical connection	Figure 5	Figure 5	Figure 5	-

<b>Limit switch SN</b>	824 . [ ] [ ] [ ] [ ] - [ ] [ ] <b>2</b> [ ]			
Safety version	2 wire connection to DIN 19234 (NAMUR) for connected switching amplifier in safety version			-
2 slot initiators	Type SJ3,5-SN			-
Function	Break contact (NC, normally closed)			-
Hysteresis	≤ 1 %			-
Control loop	See connected switching amplifier			-
Explosion protection zone 1+2 (gas)	-		II 2 G EEx ia IIC T6 ④	-
EC type-examination certificate	-		PTB 00 ATEX 2049 X	-
EMC acc. to	EN 60947-5-2 and DIN 19234			-
Electrical connection	Figure 5	Figure 5	Figure 5	-

<b>Limit switch E2</b>	824 . [ ] [ ] [ ] [ ] - [ ] [ ] <b>3</b> [ ]			
Direct switching version	3 wire connection with integrated switching amplifier			-
2 slot initiators	Type SB3,5-E2			-
Function	Make contact (NO, normally open)			-
Hysteresis	≤ 1 %			-
Supply voltage	10...30 V DC			-
Max. load current	100 mA			-
Electrical connection	Figure 6	Figure 6		-

# Technical Data Sheet

## Positioner Type 824

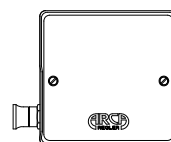

TD\_824

### Electrical data options – potentiometer and position feedback

Version	824.P ...	824.E ...	824.X ...	824.D ...
---------	-----------	-----------	-----------	-----------

Potentiometer	824	.					-				2	
Resistance	200, 500 or 1000 Ohm ⑤											
Deviation of characteristic	$\leq 2\%$ ⑥											
Internal capacitance $C_i$	3,5 pF											
Internal inductance $L_i$	10 $\mu$ H											
Explosion protection	-					EEx i ⑦			-			
EC type-examination certificate	-					not necessary			-			
Electrical connection	Figure 7			Figure 7			Figure 7			-		

Position transmitter 3w	824	.					-				3	
3 wire connection	RWG, type 4522											
Supply voltage	15...24 V DC											
Output	4(0) - 20 mA, short-circuit resistant											
Current limitation	at ca. 28 mA											
Load resistance $R_i$	0 - 400 Ohm											
Deviation of characteristic.	$\leq 2\%$ ⑥											
Electrical connection	Figure 8			Figure 8			-			-		

Position transmitter 2w	824	.					-				4	
2 wire connection	RWG, type TMT 136R											
Supply voltage	8,5 ... 36 V DC											
Output	4 - 20 mA, short-circuit resistant											
Current limitation	at ca. 36 mA											
Load resistance $R_i$	1300 Ohm at 36 V DC											
Deviation of characteristic.	$\leq 2\%$ ⑥											
Explosion protection	-					-			-			
EC type-examination certificate	-					-			-			
Electrical connection	Figure 9			Figure 9			-			-		

- ① Valid ambient temperature at other loops on request
- ② Special version to -40° C (dew point < -50°C)
- ③ Special version NPT 1/4"
- ④ Only by connection to valid switching amplifier
- ⑤ Adjustment of zero point and range at receiver terminal
- ⑥ Deviation of characteristic depends on mounting and stroke, max. 5 %
- ⑦ Passive element, therefore an EC type-examination certificate is not required. The valid external inductance and capacitance ( $L_a$  u.  $C_a$ ) must be higher than  $L_i$  and  $C_i$  of the potentiometer

# Technical Data Sheet Positioner Type 824

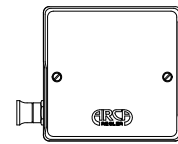

TD\_824

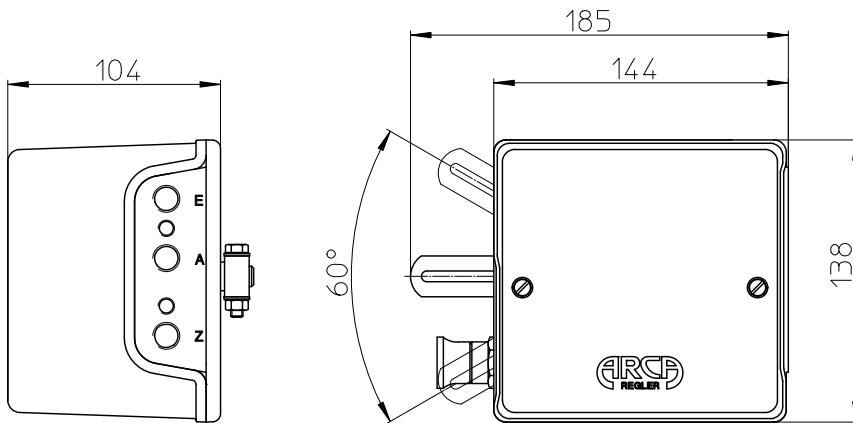

Figure 1 Dimensional drawing basic device type 824.P, 824.E and 824.X

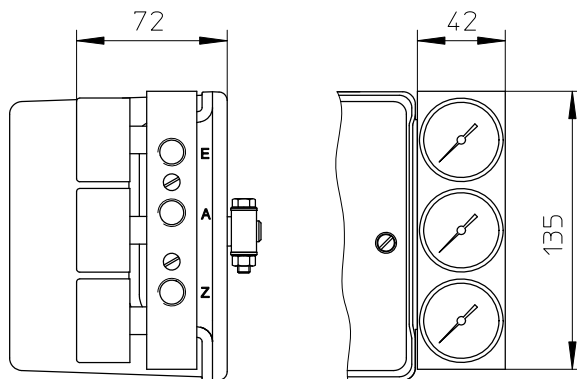

Figure 2 Dimensional drawing pressure gauge block

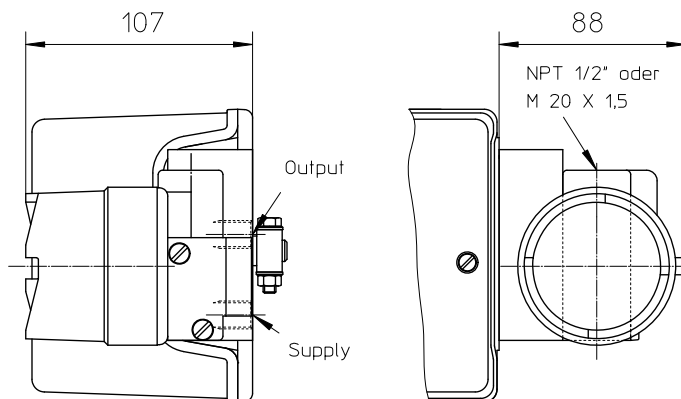
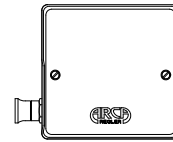
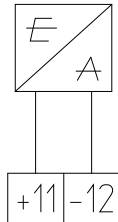

Figure 3 Dimensional drawing flame-proof type 824.D

# Technical Data Sheet Positioner Type 824



**TD\_824**



4 – 20 mA

Figure 4 Electrical connection signal input basic device, type 824.E, 824.X and 824.D

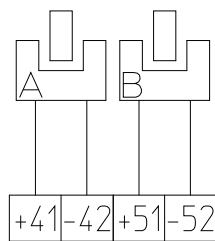

Figure 5 Electrical connection 2 wire limit switch (N and SN)

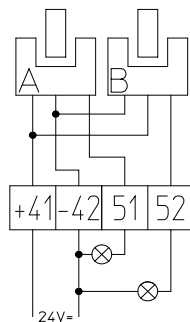

Figure 6 Electrical connection 3 wire limit switch (E2)

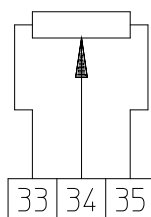
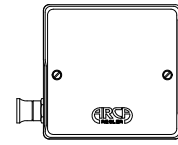

Figure 7 Electrical connection feedback potentiometer

# Technical Data Sheet Positioner Type 824



TD\_824

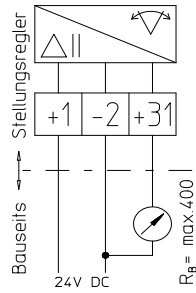

Figure 8 Electrical connection 3 wire position transmitter

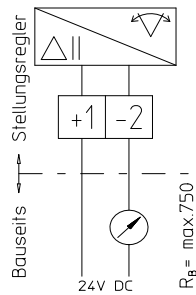
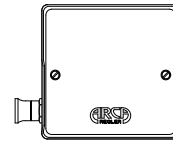

Figure 9 Electrical connection 2 wire position transmitter

# Technical Data Sheet Positioner Type 824



**TD\_824**

## Order keys

8 2 4 . P 0 0 0 - 0 0 0

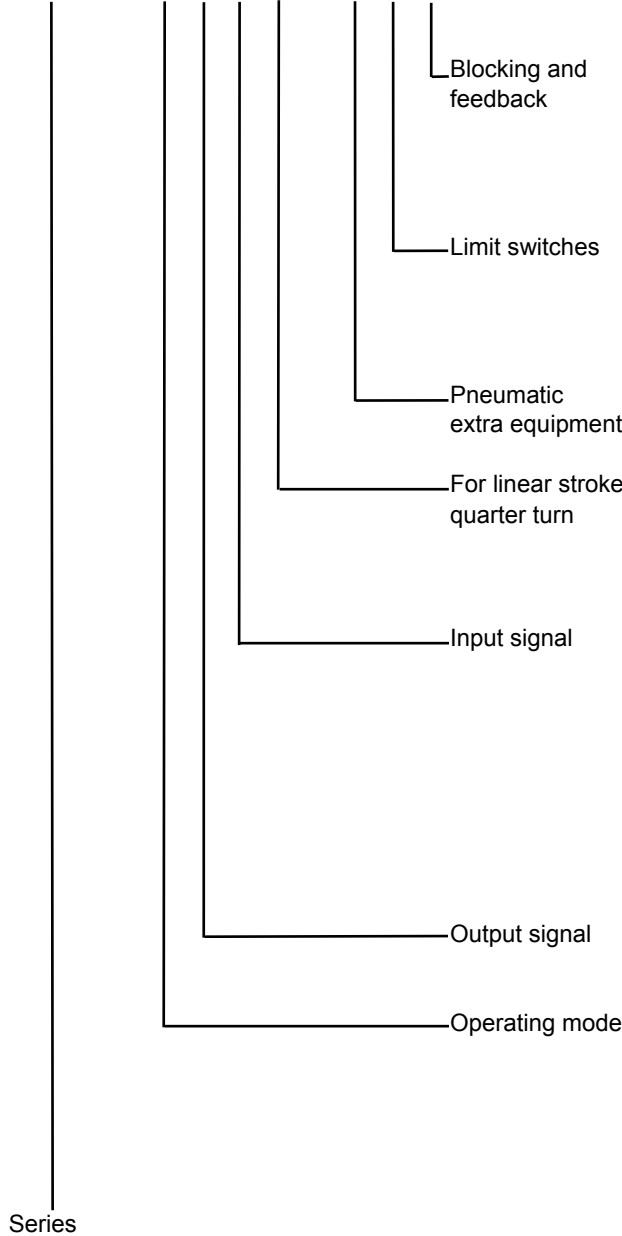

- |          |   |
|----------|---|
| <b>0</b> | without                                     |
| <b>1</b> | ./.   |
| <b>2</b> | Potentiometer                               |
| <b>3</b> | Position transmitter 3 wire                 |
| <b>4</b> | Position transmitter 2 wire                 |
|          |   |
| <b>0</b> | without                                     |
| <b>1</b> | inductive normal version SJ3,5-N            |
| <b>2</b> | inductive safety version SJ3,5-SN           |
| <b>3</b> | inductive direct switching SB3,5-E2         |
|          |   |
| <b>0</b> | without                                     |
| <b>1</b> | pressure gauge block                        |
|          |   |
| <b>0</b> | Stroke $\geq$ 20mm                          |
| <b>1</b> | Stroke < 20mm                               |
| <b>3</b> | Angle of rotation 90°                       |
| <b>4</b> | Angle of rotation 60°                       |
|          |   |
| <b>0</b> | 0,2-1,0 bar                                 |
| <b>1</b> | 4-20 mA                                     |
| <b>2</b> | 0-20 mA                                     |
| <b>3</b> | 0,2-0,6 bar                                 |
| <b>4</b> | 0,6-1,0 bar                                 |
| <b>5</b> | 4-12 mA                                     |
| <b>6</b> | 12-20 mA                                    |
| <b>7</b> | 0-10 mA                                     |
| <b>8</b> | 10-20 mA                                    |
|          |   |
| <b>1</b> | single acting                               |
| <b>2</b> | double acting                               |
|          |   |
| <b>P</b> | pneumatic                                   |
| <b>E</b> | electro-pneumatic, not explosion-proof      |
| <b>X</b> | electro-pneumatic, intrinsically safe EEx i |
| <b>D</b> | electro-pneumatic, flame-proof EEx d        |